

Tripod Turnstile

User's Manual



V1.0.3





Foreword

General

This manual introduces the functions and operations of the Tripod Turnstile (hereinafter referred to as "the Turnstile").

Safety Instructions

The following signal words might appear in the manual.

Signal Words	Meaning
 DANGER	Indicates a high potential hazard which, if not avoided, will result in death or serious injury.
 WARNING	Indicates a medium or low potential hazard which, if not avoided, could result in slight or moderate injury.
 CAUTION	Indicates a potential risk which, if not avoided, could result in property damage, data loss, reductions in performance, or unpredictable results.
 TIPS	Provides methods to help you solve a problem or save time.
 NOTE	Provides additional information as a supplement to the text.

Revision History

Version	Revision Content	Release Time
V1.0.3	Update safeguards and warnings.	December 2024
V1.0.2	Update installation requirements.	August 2024
V1.0.1	Update installation precautions.	August 2023
V1.0.0	First Release.	June 2023

Privacy Protection Notice

As the device user or data controller, you might collect the personal data of others such as their face, audio, fingerprints, and license plate number. You need to be in compliance with your local privacy protection laws and regulations to protect the legitimate rights and interests of other people by implementing measures which include but are not limited to: Providing clear and visible identification to inform people of the existence of the surveillance area and provide required contact information.

About the Manual

- The manual is for reference only. Slight differences might be found between the manual and the product.
- We are not liable for losses incurred due to operating the product in ways that are not in compliance with the manual.
- The manual will be updated according to the latest laws and regulations of related jurisdictions. For detailed information, see the paper user's manual, use our CD-ROM, scan the QR code or visit our official website. The manual is for reference only. Slight differences might be found between the electronic version and the paper version.
- All designs and software are subject to change without prior written notice. Product updates might result in some differences appearing between the actual product and the manual. Please contact customer service for the latest program and supplementary documentation.
- There might be errors in the print or deviations in the description of the functions, operations and technical data. If there is any doubt or dispute, we reserve the right of final explanation.
- Upgrade the reader software or try other mainstream reader software if the manual (in PDF format) cannot be opened.
- All trademarks, registered trademarks and company names in the manual are properties of their respective owners.
- Please visit our website, contact the supplier or customer service if any problems occur while using the device.
- If there is any uncertainty or controversy, we reserve the right of final explanation.

Important Safeguards and Warnings

This section introduces content covering the proper handling of the Turnstile, hazard prevention, and prevention of property damage. Read carefully before using the Turnstile, comply with the guidelines when using it, and keep the manual safe for future reference.

Transportation Requirement



Transport the device under allowed humidity and temperature conditions.

Storage Requirement



Store the device under allowed humidity (40%–65% (RH)) and temperature (0°C–+40°C) conditions.

Installation Requirements



- Do not connect the power adapter to the Turnstile while the adapter is powered on.
- Do not connect the Turnstile to two or more kinds of power supplies, to avoid damage to the Turnstile.
- Please follow the electrical requirements to power the device.
 - ◇ Following are the requirements for selecting a power adapter.
 - The power supply must conform to the requirements of IEC 60950-1 and IEC 62368-1 standards.
 - The voltage must meet the SELV (Safety Extra Low Voltage) requirements and not exceed ES-1 standards.
 - When the power of the device does not exceed 100 W, the power supply must meet LPS requirements and be no higher than PS2.
 - ◇ We recommend using the power adapter provided with the device.
 - ◇ When selecting the power adapter, the power supply requirements (such as rated voltage) are subject to the device label.



- Install the Turnstile on a stable surface to prevent it from falling.
- Do not place the Turnstile in a place exposed to sunlight or near heat sources.
- Keep the Turnstile away from dampness, dust, and soot.
- Install the device in a well-ventilated place, and do not block its ventilation.
- Use an adapter or cabinet power supply provided by the manufacturer.
- The Turnstile is a class I electrical appliance. Make sure that the power supply of the Turnstile is connected to a power socket with protective earthing.

Operation Requirements



- Make sure that the power supply is correct before use.
- Do not unplug the power cord on the side of the Turnstile when the adapter is powered on.
- Operate the Turnstile within the rated range of power input and output.
- Transport, use and store the device under allowed humidity and temperature conditions.
- Do not drop or splash liquid onto the Turnstile, and make sure that there is no object filled with liquid on the Turnstile to prevent liquid from flowing into it.
- Do not disassemble the Turnstile without professional instruction.
- When the Turnstile is used with access controller and the lock port connects to the K1 or K2 port of the main control board, configure the unlock duration for the access controller as 0.2 seconds.
- Prepare a separate power adapter when install a face recognition access controller.

Maintenance Requirements



- After the installation, remove the protective film and clean the Turnstile.
- Regularly perform maintenance on the Turnstile to ensure that it works properly.
- If the Turnstile is installed near places with poor air, such as a swimming pool entrance, within 50 km of the sea or a construction site, then maintenance must be performed more frequently on the stainless cover.
- Do not use paint thinner or any other organic agent during maintenance.
- When using a face detection component, apply waterproof silicon sealant to the installation position.

Precautions



- Pregnant women, the elderly, and children must be accompanied when passing the Turnstile.
- Children less than the height of 1 m must pass the Turnstile in the arms of or alongside an adult.
- Do not stay or play in the passage.
- Make sure that your suitcase passes in the front or alongside you.
- Only one person can pass through at a time. Do not tailgate a person, linger in the passage or break through the passage.
- Violent impact might damage the machine core and shorten the service life of the Turnstile.
- Make sure that the Turnstile is correctly grounded to prevent personal injury.
- Do not use the Turnstile when thunder occurs.



- When authorizing a person to pass through the Turnstile, there should be no person on the opposite side of the Turnstile, otherwise the barriers will remain unlocked until the person on the opposite side exits.
- Pass through the Turnstile as soon as possible after authorization. If the person does not enter within the specified time, the system will automatically close the barriers.

- When multiple persons are entering, they can pass with continuous authorization when memory mode is enabled. But the interval between continuous authorizations is recommended to be 2 s–5 s.
- Pay attention to the status of the indicator when verifying a person's identity. Red indicates that the identity of the person was not verified. Green indicates that their identity was successfully verified, and that the person can pass through.
- Do not try to forcibly pass through the passage. This Turnstile supports intelligent anti-tailgating and anti-reverse intrusion. If you forcibly break through, the system will automatically lock, closing off the passage. This can result in a person becoming injured.
- The Turnstile will not correctly recognize the authorized card if it is used together with other cards.
- Keep the authorized card well to make sure it works properly.
- Do not pass items through the Turnstile, otherwise the Turnstile will consider the item as unauthorized.
- If the Turnstile is used with the face recognition access controller, when the lock port on the face recognition access controller is connected to the K1 or K2 port on the main control board on the Turnstile, the unlock duration for the face recognition access controller should be configured as 0.2 seconds.
- If the Turnstile is used with the face recognition access control device, the separate power adapter must be prepared.

Table of Contents

Foreword.....	I
Important Safeguards and Warnings.....	III
1 Product Introduction.....	1
1.1 Product Overview.....	1
1.2 Dimensions.....	1
1.3 Components.....	2
1.4 Passage Combination Modes.....	3
2 Installation.....	5
2.1 Installation Requirements.....	5
2.2 Installation Environments.....	6
2.3 Installation Procedure.....	6
2.3.1 Drilling Holes.....	6
2.3.2 Opening the Turnstiles.....	7
2.3.3 Wiring the Cables.....	9
2.3.4 Securing the Turnstiles.....	10
2.4 Main Control Board Wiring.....	11
3 Configuring and Debugging.....	12
3.1 Menu Functions.....	12
3.1.1 Passage Mode.....	13
3.1.2 Memory Mode.....	14
3.2 Power-On Self-test.....	14
Appendix 1 Maintenance.....	15
Appendix 2 Stainless Steel Maintenance Measures.....	17
Appendix 2.1 Rust and Degumming Prevention.....	17
Appendix 2.2 Removing Marks and Rust.....	17
Appendix 2.3 Notice.....	18
Appendix 3 Security Recommendation.....	19

1 Product Introduction

1.1 Product Overview

The Turnstile is widely used to control and guide the access crowd for certain buildings or locations, such as in construction sites, scenic areas and factories. When the Turnstile is powered off, people can pass through it easily as the sticks loosen. When it is powered on, passengers need to press down the swivel stick and then lift it up.

1.2 Dimensions

Figure 1-1 Dimensions (unit: mm [inch])

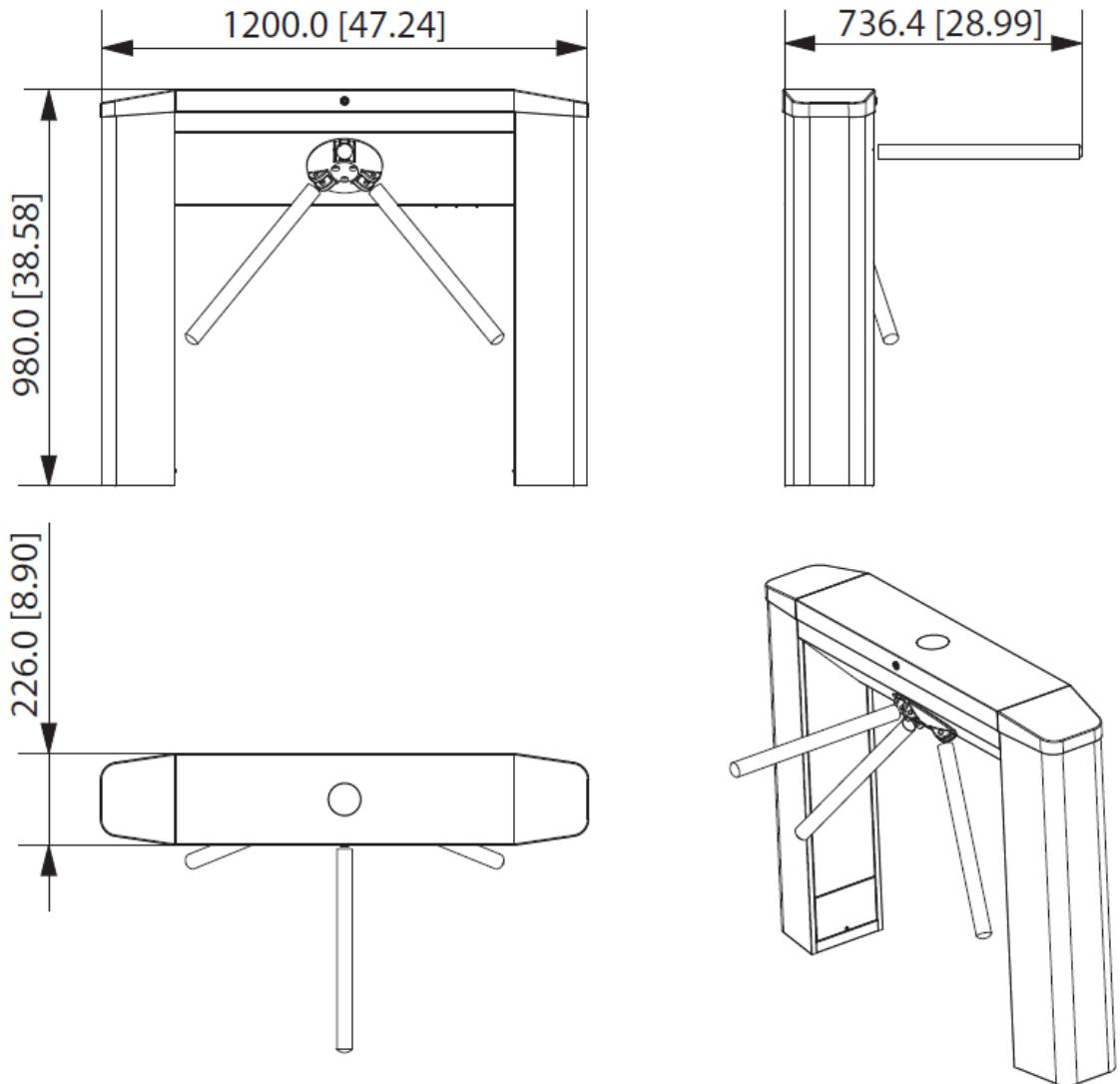

1.3 Components

Figure 1-2 Components

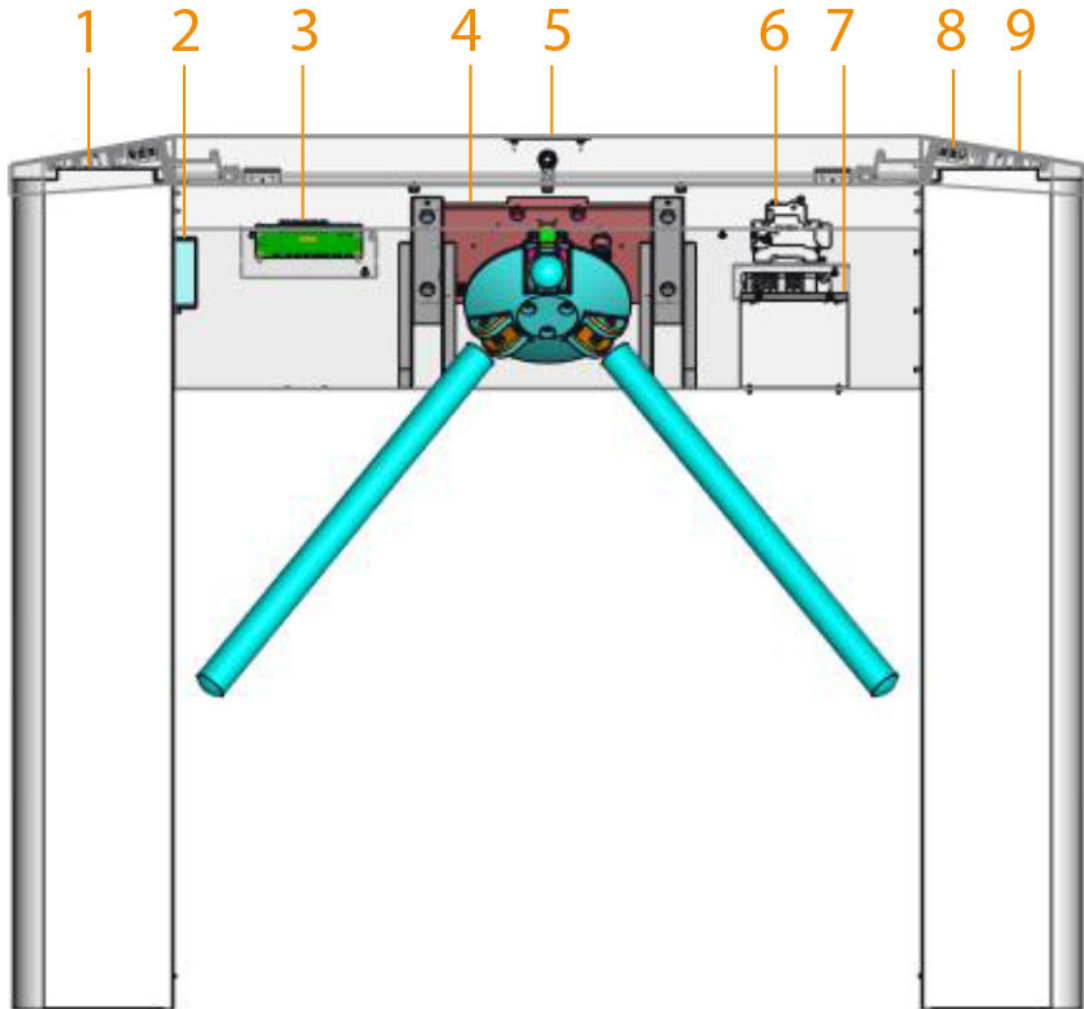

Table 1-1 Components

No.	Component	Description
1	Card Reader Board	Used for swiping the cards.
2	Fan	Used for heat dissipation and anti-condensation.
3	Main Control Board	Receives signals from the access control board, and send execution commands to the channels after doing logical judgment and processing of the signals.
4	Mechanism	The mechanism consists of electromagnet, rotary unit, roller and other components. Rotate the arm to pass.

No.	Component	Description
5	Lane Indicator	<p>Indicates whether passengers are allowed to pass the current turnstile, and the passage modes.</p> <ul style="list-style-type: none"> ● One-way free passage: The unidirectional arrow is solid on. ● Fire control mode: The bidirectional arrow is solid on. ● Authorized passage mode: Follow the direction that the arrow points to. ● Authorized no passage mode: The red indicator for forbidden passage is solid on. ● Free passage mode: The bidirectional arrow is solid on.
6	Circuit Breaker	When a power leakage or power outage occurs, the main power supply will be cut off automatically.
7	Power Supply	Converts the input power to 24 VDC.
8	Face Recognition Access Terminal	You can assign access permissions to it for identification or it can be used as a card reader.
9	Antenna Board	A place for people to swipe their cards.



The cabinet does not include all electronic materials such as mechanism, main control board, and air switch.

1.4 Passage Combination Modes

It can be divided into three combination modes: single channel, dual channel and multi-channel.

Three combination methods are selected according to the position against the wall.

Figure 1-3 Combination modes

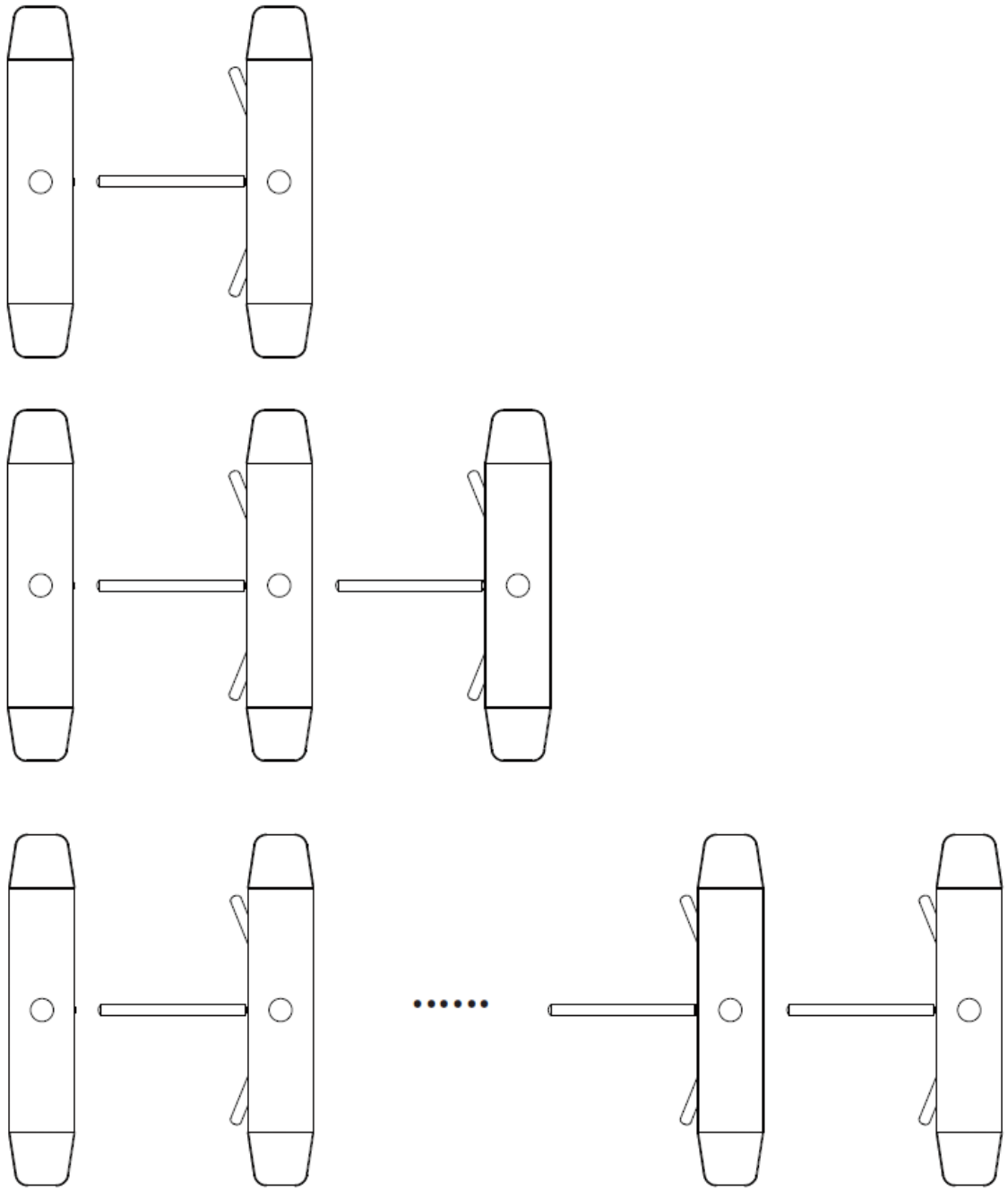

2 Installation

2.1 Installation Requirements

Precautions



WARNING

- You need to strictly confirm to requirements in the manual during installation; otherwise we assume no responsibility for any loss occurred.
- Incorrect installation and improper operation might cause damage to humans or objects.
- Security devices and control devices used must follow EN12978 standards.
- Power off the Turnstile before you install, wire, or disassemble the Turnstile.
- The Turnstile consists of various mechanical and electrical modules, any neglect during installation might cause damage.
- If smoke, strange smell or noises come out from the Turnstile, cut the power off immediately, and then contact the distributor or service center.
- To avoid personal injuries and damage to the Turnstile, do not disassemble the outer cover if not necessary.
- Avoid risk of fire. Install only on concrete or other non-combustible floor.
- An appropriate disconnect device shall be provided as part of the building installation.



- Make sure that the Turnstile is fixed firmly.
- When connecting to 100–240 V mains, make sure the Turnstile is properly grounded.
- Before running the Turnstile, make sure that the user or operator can fully observe its status.
- Do not stand in the lane to operate the Turnstile when it is powered on.

Preparations

- Make sure that the ground where the Turnstile is installed is flat.
- Build a concrete base with the height of 50 mm-150 mm (depending on the circumstance) when the Turnstile is installed at places prone to high humidity or water accumulation. Apply silicone sealant to gaps between the concrete base and Turnstile to prevent water and condensation.
- Make sure the PVC pipe buried in the ground is deeper than 150 mm, and the PVC pipe must be more than 50 mm above the ground. Bend the PVC pipe end above the ground to prevent water leakage. Keep the ground where the Turnstile is installed dry.
- Keep the installation area clear after the Turnstile is installed.
- Prepare an ideal installation location based on the passage width and installation diagrams.

Tools

Tools might vary depending on installation locations.

- Cement ground
 - Electric hammer drill, No.16 drill bit, marker, tape measure, spirit level, plumb bob, hammer, wrench, angle grinder, cut-off saw, and screwdriver.
- Marble and ceramic ground

Because marble and ceramic ground are fragile, you need to use electric hand drill to drill small holes in the marble and ceramic ground, and then drill round holes after adding some cooling water. Flush off the remains in the holes and drill again for a proper size.

2.2 Installation Environments

Before installing the Turnstile next to buildings, leave some space between the Turnstile and the buildings.



- Do not place the Turnstile in the wrong direction.
- When installing turnstiles next to buildings, make sure that their distance (M) is not less than 60 mm and not more than 100 mm (depending on the circumstance). This distance is sufficient for the Turnstile cover to be opened during maintenance, and prevents people from passing through the gap between the turnstiles and buildings.

Figure 2-1 Spacing requirements

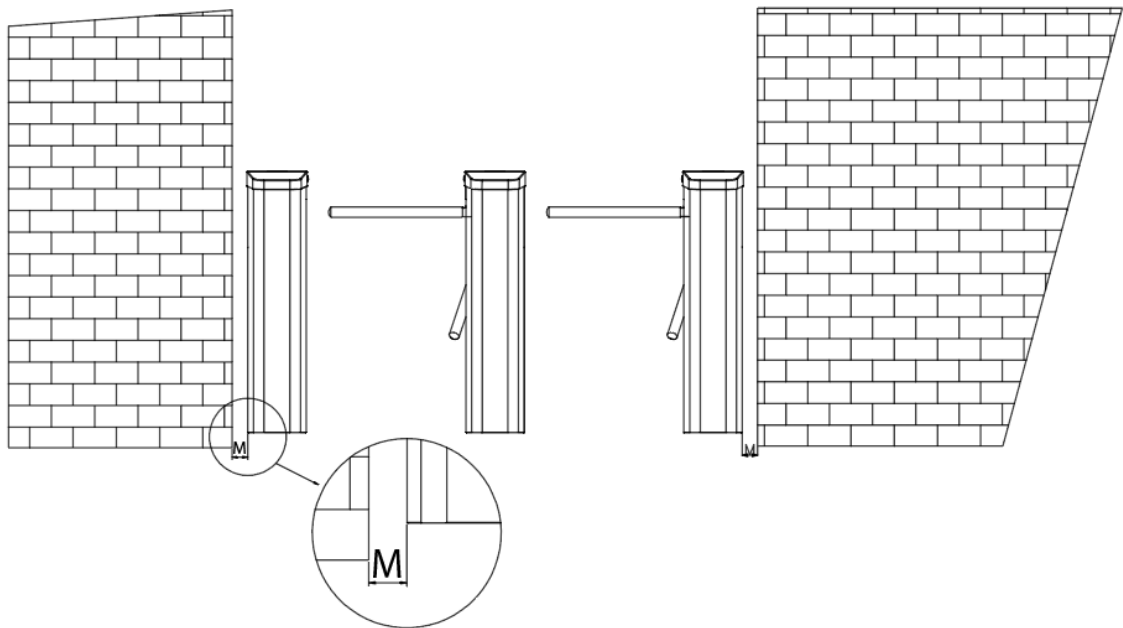

2.3 Installation Procedure

2.3.1 Drilling Holes

Procedure

- Step 1 Mark 4 installation holes on each turnstile.

Figure 2-2 Hole drilling diagram (mm [inch])

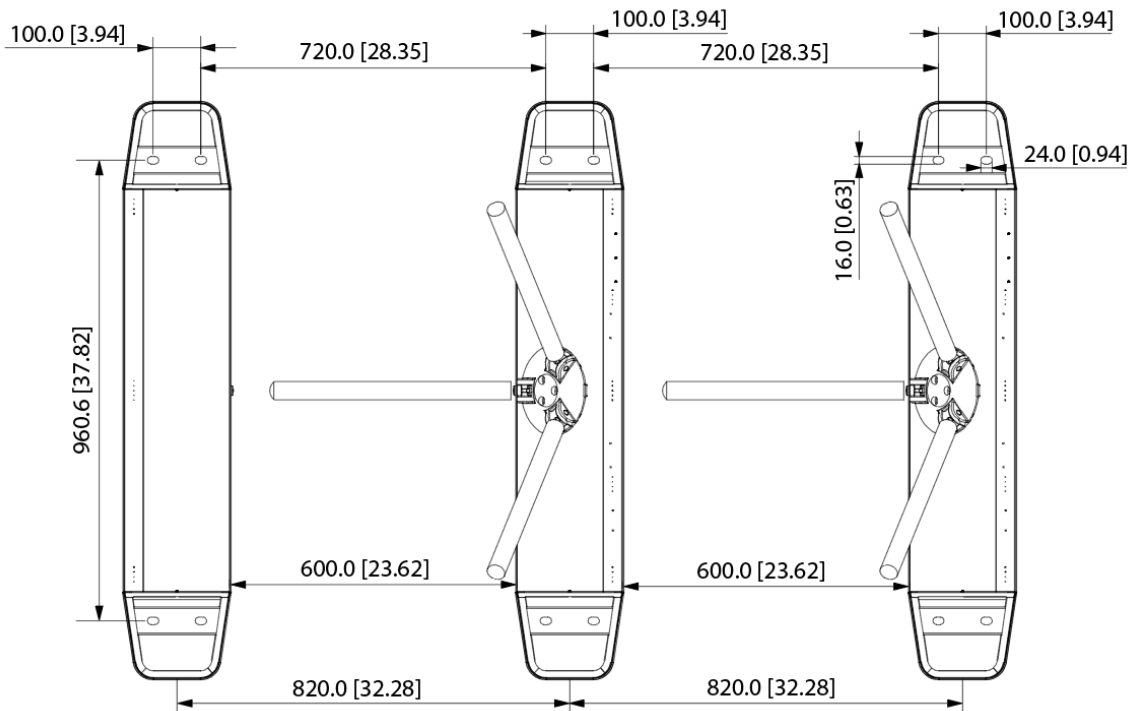

Step 2 Drill holes in the installation surface (like cement).

Table 2-1 Expansion bolts

Parameter	Dimensions
Expansion bolt specification	M12 × 120
Hole depth (mm)	95
Hole diameter (mm)	16

Step 3 Use air pump to remove the remaining dust in the holes. Repeat the operation for at least 3 times.

Step 4 Hammer the expansion bolt into the hole to make sure it remains in place.

Step 5 Tighten the nut with a wrench until the bolt expands, and then hammer it again to make sure it is in place.

2.3.2 Opening the Turnstiles

Procedure

Step 1 Use the key to unlock the upper cover, and then use the screwdriver to open the side panel.

Figure 2-3 Turnstile doors

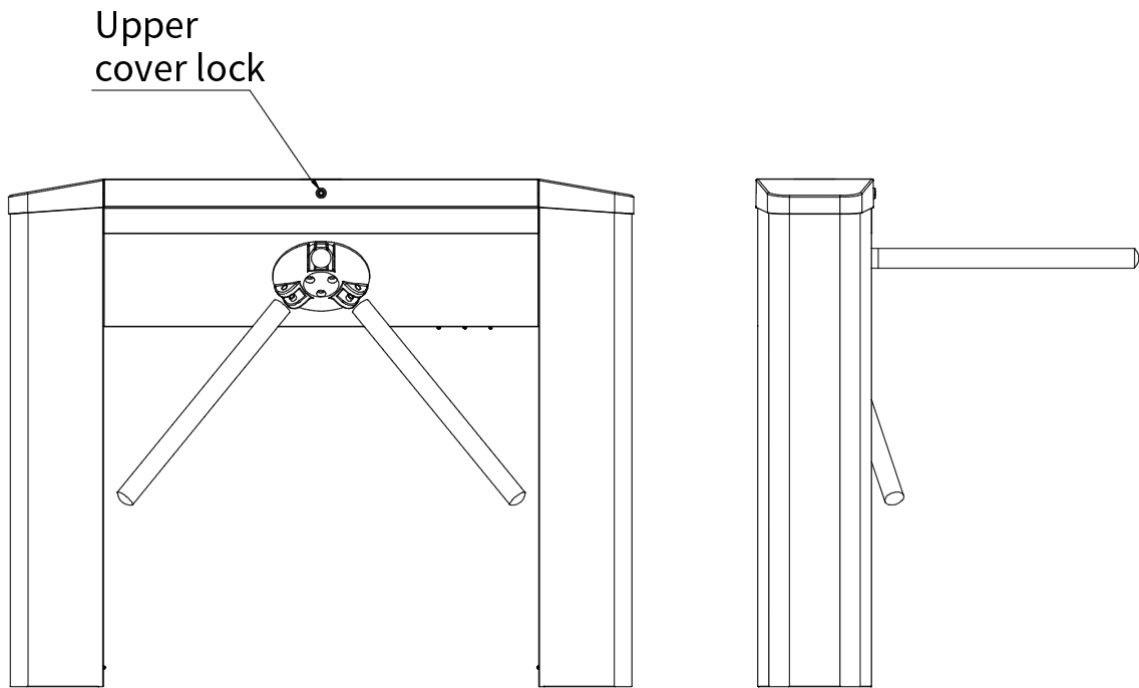

Step 2 Thread the wires through the wiring slot (32 mm in diameter), and keep the wires organized to avoid wire breaking.

Figure 2-4 Wiring slot

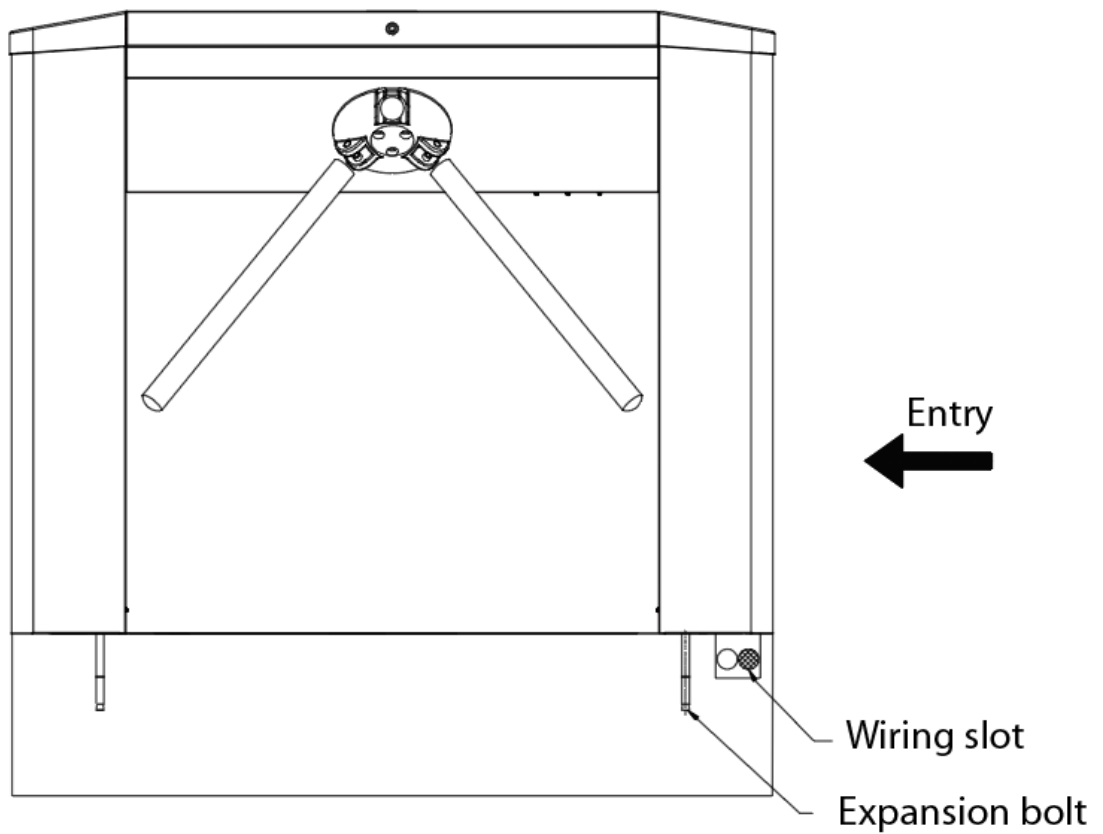

- Step 3** Lift the Turnstile, and adjust the position to align the installation hole of the Turnstile with the expansion bolt, and place it on the installation surface.
- Step 4** Adjust the Turnstile to make sure it is horizontally placed.
- Step 5** Select three points vertically or horizontally on the Turnstile, and then measure the horizontal level of the Turnstile with a spirit level.
- Step 6** Repeat **Step 1** to **Step 5** to install other turnstiles.



- Arrows on the top cover of Turnstiles must point in the same direction.
- Make sure that the turnstiles are parallel to each other, and the height difference is within an appropriate range.

2.3.3 Wiring the Cables

The power wire, interconnecting cables and network cables should be buried in the ground.

Wiring

- The wires must be clearly labeled before wiring.
- Make sure that the AC power wire, interconnecting cable and network cable are separately placed in the PVC pipes (strong current and weak current must not be in the same pipe).
- Make sure the PVC pipe buried in the ground is deeper than 150 mm, and the PVC pipe must be more than 50 mm high above the ground to avoid water leakage.
- The PVC pipes must be threaded through the slot of the installation base.
- The pipe diameter for the interconnecting cable must be more than 30 mm.

Figure 2-5 Wiring diagram

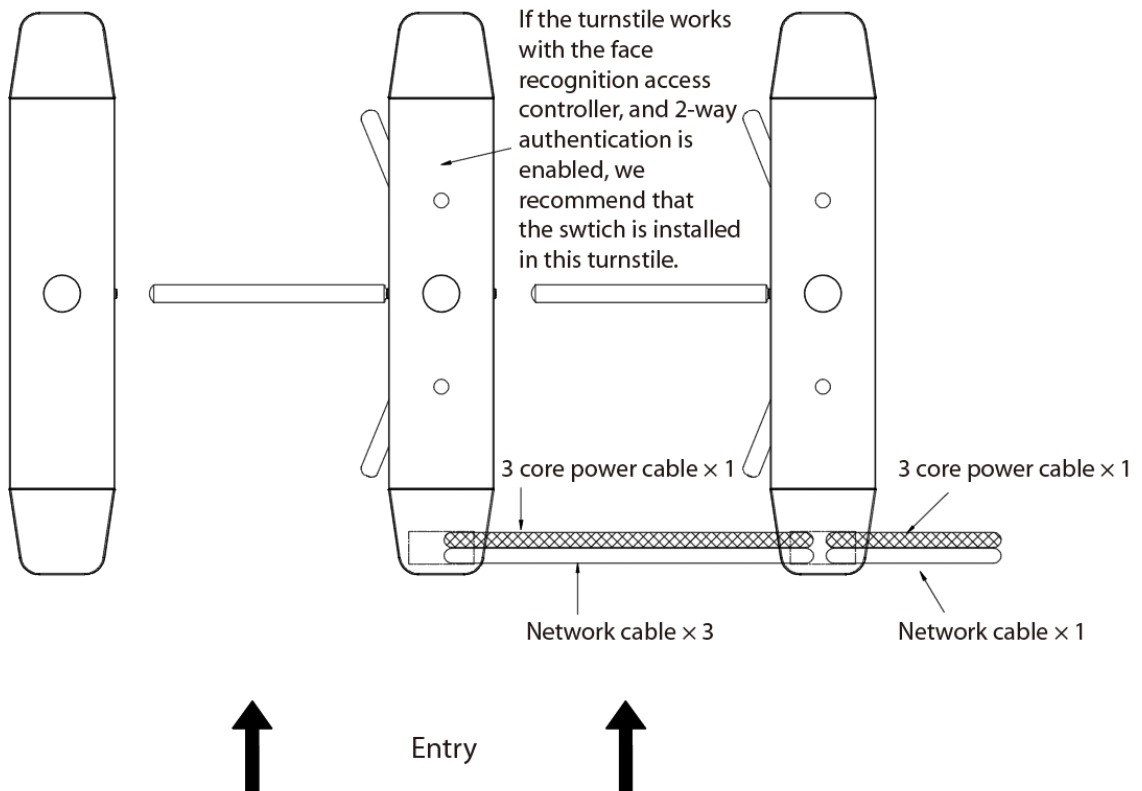



Table 2-2 Cable connection

Icon	Cable type	Description
	Power wire (14AWG.LNPE)	Connect a 220 V power wire (RVV3 × 2.5) for each turnstile. Leave the power wire 3 meters long after threading it through the wiring slot. Use the 32 mm light PVC conduit.
	Network cable (CAT5)	By default, a network cable is connected. The number of network cables is subject to the number of access control boards. Leave the network cable 3 meters long after passing it through the wiring slot. Use the 32 mm light PVC conduit.

Wiring Effect

The Turnstile should be installed in accordance with the recommended wiring method, and it is strictly prohibited to connect pipes and wiring according to the wrong wiring path diagram. Otherwise, the Turnstile will not be firmly fixed, which affects the reliability of the operation of the Turnstile. Worse still, the wrong method would lead to threading during the installation of wall plug holes.

2.3.4 Securing the Turnstiles

Procedure

- Step 1** After adjustment, put the flat washer, spring washer, and nut into the bolt, and then tighten the nut manually.
- Step 2** Tighten all the nuts with a wrench.
- Step 3** Apply silicone sealant to gaps between the Turnstile and the ground to avoid water leakage.

Figure 2-6 Secure turnstiles

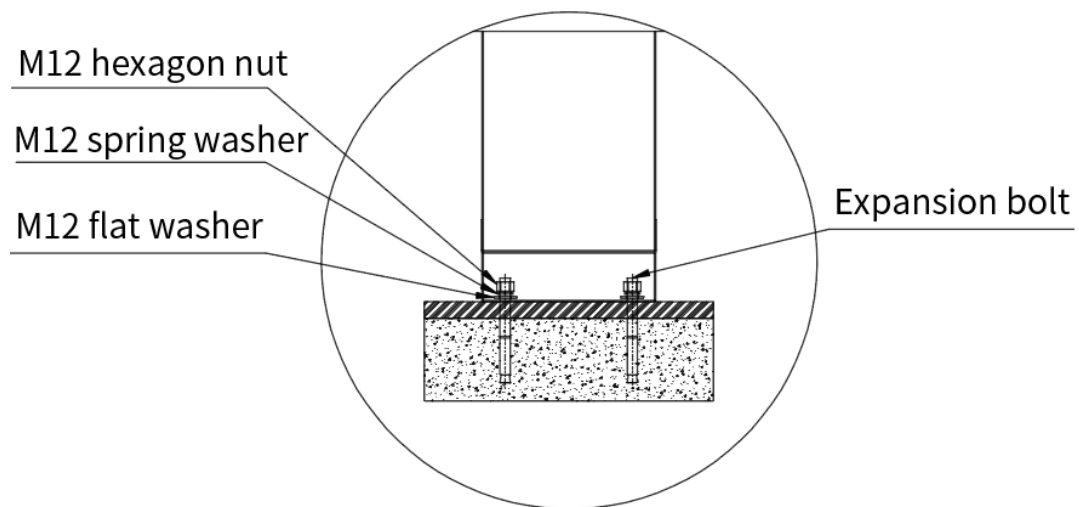

2.4 Main Control Board Wiring

Figure 2-7 Main control board

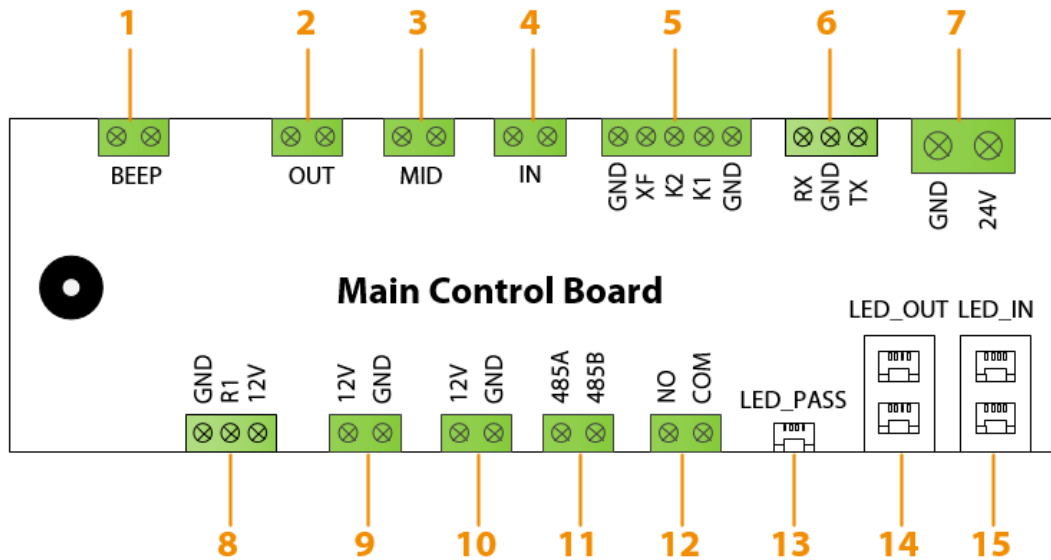

Table 2-3 Port description of the main control board

Port No.	Description
1	External buzzer control port.
2	Power port of the electromagnet for the exit.
3	Power port of the suction cup electromagnet.
4	Power port of the electromagnet for the entrance.
5	The port for the opening and closing signal and the firefighting signal.
6	RS232 communication port to connect to face recognition access terminal.
7	24 VDC power supply port that connects to the power supply.
8	Proximity switch port.
9	Power port for the fan.
10	Power port for the face recognition access controller and the access reader.
11	RS-485 port.
12	Alarm output port.
13	Lane indicator port for the upper cover.
14	Lane indicator port for the column. LED_IN means the entrance direction. (Reserved)
15	Lane indicator port for the column. LED_OUT means the exit direction. (Reserved)

3 Configuring and Debugging

3.1 Menu Functions

The tripod turnstile is sold with the access reader accessory and the access controller accessory. The default passage mode of the factory device is controlled passage/controlled passage.



Use the configuration application to modify the mode. For example, you can use ConfigTool.

Table 3-1 Menu functions

Name	Parameter	Description
Passage modes	<ul style="list-style-type: none"> ● 01: Controlled passage/controlled passage (default) ● 02: Controlled passage/free passage ● 03: Controlled passage/no passage ● 04: Free passage/controlled passage ● 05: Free passage/free passage ● 06: Free passage/no passage ● 07: No passage/controlled passage ● 08: No passage/free passage ● 09: No passage/no passage 	<ul style="list-style-type: none"> ● Controlled passage: Enter or exit after the identity is successfully verified. ● Free passage: All people are allowed to pass without their identity being verified. ● No passage (direction closed): Nobody is allowed to enter the passage, even if their identity is successfully verified.
Memory mode	<ul style="list-style-type: none"> ● 01: Turn off ● 02: Turn on (default) 	Continuously verifies the identity of people when a lot of people have to pass through the passage.
Update	Supports update.	—
Firefighting signal	The arm drops when there is the firefighting signal.	—
The arm drops when powered off	The arm drops when the device is powered off.	—
Lane indicator	Indicates the passage mode. <ul style="list-style-type: none"> ● Unidirectional free passage mode: The unidirectional arrow is solid on. ● Firefighting mode: The bi-directional arrow is solid on. ● Authorized passage mode: The arrow indicates the passage direction. ● Authorized no passage mode: The red x is solid on. ● Free passage mode: The bi-directional arrow is solid on. 	—
Restore to factory default	<ul style="list-style-type: none"> ● 01: Turn off (default) ● 02: Turn on 	The turnstile supports restoring to factory default.

3.1.1 Passage Mode

Configure the passage mode according to the controlled area.

- Controlled passage: Enter/exit after valid identity verification.
- Free passage: All people are allowed to pass without identity verification.
- No passage (direction closed): No passage is allowed.



- Enter: Enter the controlled area.
- Exit: Exit from the controlled area.

Figure 3-1 Passage mode

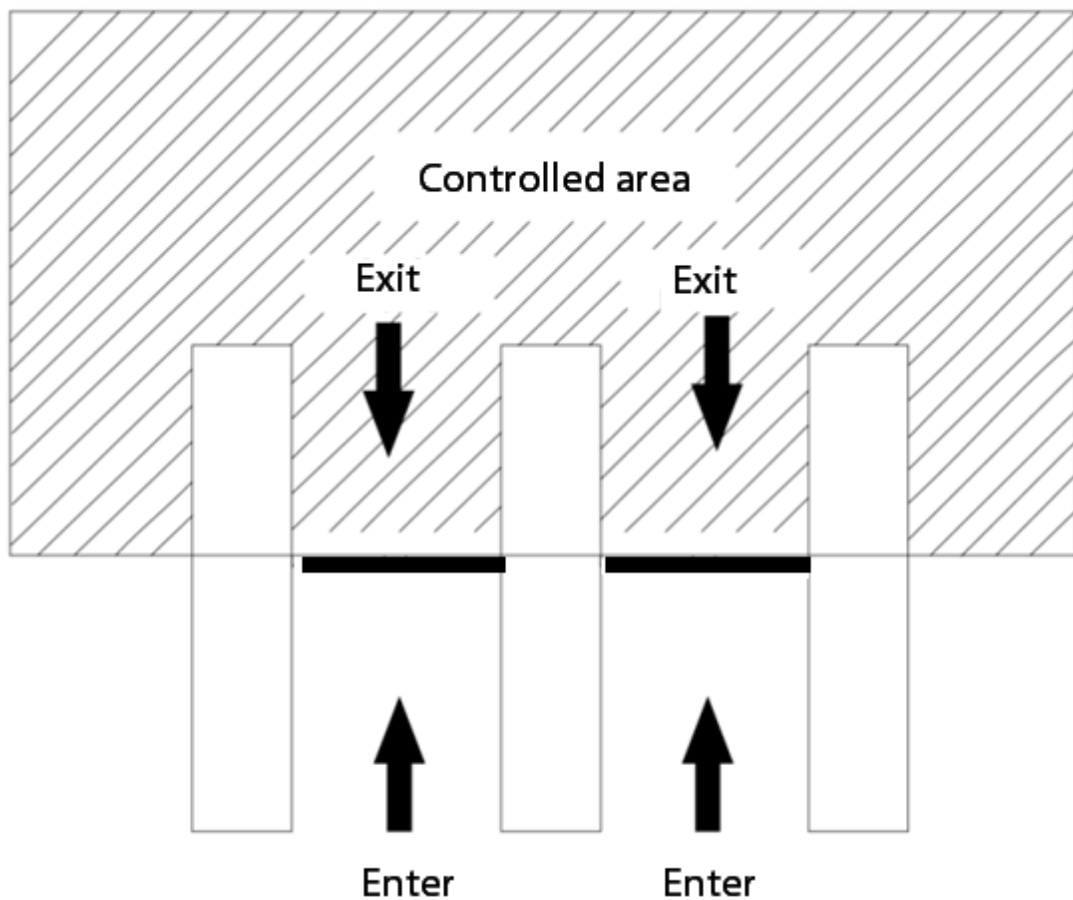

You can set any of these 9 passage combinations which are based on the 3 main passage modes:

- Controlled entry and controlled exit (default).
- Controlled entry and free exit.
- Controlled entry and no exit.
- Free entry and controlled exit.
- Free entry and free exit.
- Free entry and no exit.
- No entry and controlled exit.
- No entry and free exit.
- No entry and no exit.

3.1.2 Memory Mode

You can turn on the memory mode to allow for continuous identity verification for large passenger flow.

- If multiple people are granted access, and one of them does not pass through the Turnstile in 5 s or stayed overtime on the lane, the turnstile will be locked. At this mode, you need to swipe cards several times to allow several people pass the turnstile continuously.
- After the memory mode is turned on, if the card swiping interval exceeds the defined single person passage time, the memory mode will not be triggered.
- The authorization interval must be longer than the unlock duration of the access controller and the face recognition access terminal. Otherwise, only one authorization will be counted. The recommended authorization interval is 2 s–5 s.
- In the memory mode, up to 255 people can continuously pass through the Turnstile.

3.2 Power-On Self-test

Prerequisites

Before you do the power-on self-test, check the following items:

- Check whether all components of the Turnstile are normal. The Turnstile was tested before it left the factory, but slight changes might occur during transportation and installation.
- Check whether the Turnstile is wired securely.

Procedure

Step 1 Power on the Turnstile, press down the swivel stick, and then lift it up.

Appendix 1 Maintenance

Maintain the turnstile regularly; otherwise its lifespan or performance will be influenced.



WARNING

- Do not spray water onto the Turnstile. You can wipe the turnstile only with water and other neutral liquids.
- Do not clean the exterior of the Turnstile with hard objects.
- Do not wipe and spray the turnstile with chlorine-containing disinfectant.
- Regularly check the screws attached to the mechanism and other components. Tighten the screws, and then use the threadlock glue to fix them.

Turnstile Exterior

- Cut off the power supply of the Turnstile before you clean the Turnstile. Do not wet the parts of Turnstile during cleaning.
- To avoid damages to the brushed metal surface, the cleaning agent must not contain granular abrasives.
- Maintenance cycle: We recommend you maintain the Turnstile once a month; if the turnstile is installed near the seaside or chemical companies, maintenance once a week is recommended.

Maintenance steps:

1. Clean the surface of the cabinet with the non-woven cloth moistened with water or other neutral liquids.
2. After cleaning, use stainless steel maintenance agent to wipe and maintain the whole Turnstile.

Rust removal steps:

1. Wipe the surface of the Turnstile with a scouring pad.
2. After spraying the rust remover onto the surface, leave it for 5 minutes.
3. Use a scouring pad to wipe the rust spots along the brushing direction.
4. After removing the rust, use stainless steel maintenance agent to wipe and maintain the entire Turnstile.

Turnstile Interior



To avoid short circuit, do not clean the internal power supply and the circuit board with water.

Maintenance cycle: Once every three months is recommended.

Maintenance steps:

1. Cut off the power, open the cover of the Turnstile, and remove the internal dust.
2. When the turnstile is installed outdoor with a face detection device, please check whether it is getting unglued. If it becomes unglued, please clean the glue and refill the glue on a sunny day. If the card swiping area also becomes unglued, fix it with the same method.
3. Apply anti-rust lubricating grease on the surface of moving parts such as bearings and retaining ring (moving parts vary with different models).
4. Check whether the circuits, cables, and connector become exposed or loose. Wrap up, straighten or tighten them. If the wires are aging, replace them.
5. Check whether the swing door and the screws of the rotating shaft are loose. If they become loose, please tighten them.

6. Check whether the motor, bearings, fasteners, and drive shaft are all tightened securely. If they get loose, please tighten them.
7. Check whether the roller and the mechanism are all tightened securely. If they get loose, please tighten them and use the threadlock glue to fix them.

Appendix 2 Stainless Steel Maintenance Measures

Appendix 2.1 Rust and Degumming Prevention

Rusty stainless steel and degumming will only happen if the turnstile is used or maintained inappropriately, or in harsh environments.

Rust Prevention

Do not expose the turnstile to substances that might cause rust to happen.

- Ions, sulfur oxide, acidic substances that contains HCL and H2SO4, or substances that produce acidic substances (such as SO4, salt, and HCLO) after dissolving in water will damage the passive film on the stainless steel.
- Substances like soot and dust will disturb the regeneration of the passive film on the stainless steel.
- Metal powder that mostly contains iron will stick to the stainless steel and get rusty.

Degumming Prevention

- After applying protective film on the stainless steel, protect it from UV rays (direct sunlight), heat, and pressure to avoid degumming.
- When installing the device using recognition components, apply silicon sealant to the installation hole to prevent water leakage, and reapply it every two years.

Appendix 2.2 Removing Marks and Rust

Removing Marks from Taking Off the Protective Film

Use sponge or cloth dipped with alcohol, naphtha, or a mixed solution of ethyl alcohol and methylbenzene (or acetone) to clean the mark from removing the protective film. These chemicals are in ascending order of intensity. Use a clean cloth to scrub the stainless steel until the solution is dried up. You can also use any other stainless steel cleaner. No matter which method you use, clean the surface thoroughly with clean water.

Removing Palm Marks

A neutral detergent or soap should be enough; otherwise, use an organic solution (such as alcohol, and naphtha). After scrubbing the surface with a solution, use a clean and dry cloth to wipe off the solution. Stainless steel cleaner is recommended.

Removing a Small Amount of Rust

Use stainless steel cleaner.

Removing a Larger Amount of Rust

If metal powder gets rusty on the stainless steel and is not removed in time, the stainless steel will get rusty itself. Also, if rust caused by salts or other rust-inducing items are not removed in time, it will get worse. For these two situations, you have to use the specialized stainless steel cleaner. If the cleaner is not good enough, use sand papers or a stainless steel brush to remove some of the rust, and be careful not to damage the stainless steel surface, and then apply the cleaner.

Appendix 2.3 Notice

Cleaning Requirements

- Cut off the power supply before cleaning the turnstile. Make sure that the components inside are dry.
- The detergent you use must not contain abrasive matter; otherwise the turnstile surface will be damaged.
- Clean along lines on the surface.
- Use cloth to dry the surface after using detergent and clean water.

Cleaner Requirements

- Select a stainless steel cleaner according to the actual situation. The cleaner with over 30% active ingredients are recommended.
- Do not use the cleaner that contains acidic substances, especially sulfuric acid, sulfurous acid, and those that contain chlorine.
- If there is degumming, use organic solutions that has no oxidative capacity. Alcohol, dimethyl benzene, and acetone are normally used.
- For stainless steel with a processed surface (mirror finish or titanium coating), make sure that you use a neutral cleaner containing no abrasive matter.

Appendix 3 Security Recommendation

Account Management

1. Use complex passwords

Please refer to the following suggestions to set passwords:

- The length should not be less than 8 characters;
- Include at least two types of characters: upper and lower case letters, numbers and symbols;
- Do not contain the account name or the account name in reverse order;
- Do not use continuous characters, such as 123, abc, etc.;
- Do not use repeating characters, such as 111, aaa, etc.

2. Change passwords periodically

It is recommended to periodically change the device password to reduce the risk of being guessed or cracked.

3. Allocate accounts and permissions appropriately

Appropriately add users based on service and management requirements and assign minimum permission sets to users.

4. Enable account lockout function

The account lockout function is enabled by default. You are advised to keep it enabled to protect account security. After multiple failed password attempts, the corresponding account and source IP address will be locked.

5. Set and update password reset information in a timely manner

The device supports password reset function. To reduce the risk of this function being used by threat actors, if there is any change in the information, please modify it in time. When setting security questions, it is recommended not to use easily guessed answers.

Service Configuration

1. Enable HTTPS

It is recommended that you enable HTTPS to access web services through secure channels.

2. Encrypted transmission of audio and video

If your audio and video data contents are very important or sensitive, it is recommended to use encrypted transmission function in order to reduce the risk of your audio and video data being eavesdropped during transmission.

3. Turn off non-essential services and use safe mode

If not needed, it is recommended to turn off some services such as SSH, SNMP, SMTP, UPnP, AP hotspot etc., to reduce the attack surfaces.

If necessary, it is highly recommended to choose safe modes, including but not limited to the following services:

- SNMP: Choose SNMP v3, and set up strong encryption and authentication passwords.
- SMTP: Choose TLS to access mailbox server.
- FTP: Choose SFTP, and set up complex passwords.
- AP hotspot: Choose WPA2-PSK encryption mode, and set up complex passwords.

4. Change HTTP and other default service ports

It is recommended that you change the default port of HTTP and other services to any port between 1024 and 65535 to reduce the risk of being guessed by threat actors.

Network Configuration

1. **Enable Allow list**

It is recommended that you turn on the allow list function, and only allow IP in the allow list to access the device. Therefore, please be sure to add your computer IP address and supporting device IP address to the allow list.

2. **MAC address binding**

It is recommended that you bind the IP address of the gateway to the MAC address on the device to reduce the risk of ARP spoofing.

3. **Build a secure network environment**

In order to better ensure the security of devices and reduce potential cyber risks, the following are recommended:

- Disable the port mapping function of the router to avoid direct access to the intranet devices from external network;
- According to the actual network needs, partition the network: if there is no communication demand between the two subnets, it is recommended to use VLAN, gateway and other methods to partition the network to achieve network isolation;
- Establish 802.1x access authentication system to reduce the risk of illegal terminal access to the private network.

Security Auditing

1. **Check online users**

It is recommended to check online users regularly to identify illegal users.

2. **Check device log**

By viewing logs, you can learn about the IP addresses that attempt to log in to the device and key operations of the logged users.

3. **Configure network log**

Due to the limited storage capacity of devices, the stored log is limited. If you need to save the log for a long time, it is recommended to enable the network log function to ensure that the critical logs are synchronized to the network log server for tracing.

Software Security

1. **Update firmware in time**

According to the industry standard operating specifications, the firmware of devices needs to be updated to the latest version in time in order to ensure that the device has the latest functions and security. If the device is connected to the public network, it is recommended to enable the online upgrade automatic detection function, so as to obtain the firmware update information released by the manufacturer in a timely manner.

2. **Update client software in time**

It is recommended to download and use the latest client software.

Physical Protection

It is recommended that you carry out physical protection for devices (especially storage devices), such as placing the device in a dedicated machine room and cabinet, and having access control

and key management in place to prevent unauthorized personnel from damaging hardware and other peripheral equipment (e.g. USB flash disk, serial port).